

MIAMI[®]

REF :
CH100 / CH101

Version shown
CH100G2

Category

Chair

Use

Interior

Model

CH100 : Fixed seat

CH101 : Swivel seat

Product sold in sets of 2



Unit : centimetre

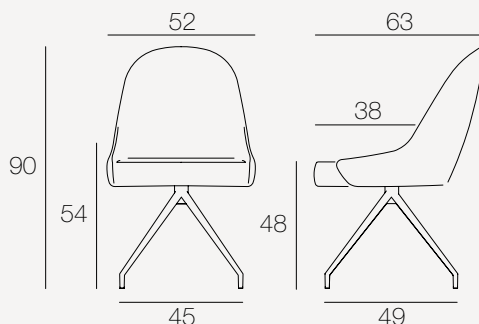

FINISHES

Fabric :



Ocher yellow



Red



Grey



Charcoal



Grey velvet



Taupe



Brown velvet



Blue

Base :



Matt black lacquered steel

TECHNICAL INFORMATION

Seat :

Seat swivels 90° or fixed seat

Light resistance : > 4

Density of foam padding : 25kg/m³

Fabric :

100% polyester fabric

Martindale : 60 000

© Registered design (INPI : 20205317)

Base :

Powder coated steel*

*Powder coating is a «dry» spraying technique that uses no solvents that are harmful to people or the environment. This technique complies with European REACH regulations, which control the use of chemicals in industry.

Net weight : 9 kg

Maximum supported weight : 120 kg

PACKAGING

Number of packages (2 chairs per package)	Gross weight (product + packaging)	Package dimensions
1	20 kg	76 x 53 x 66 cm

AKANTE[®]

www.akante.com